

Precision Digital Pressure Gauge

Model MG401

Nominal size: 100 mm (4")
Accuracy: Class 0.1 (0.1%)

Features

- 5 & 6 Digit Large LCD Display
- Bright Backlight
- 14 Standard Engineering Units
- Protection IP65
- SS316L Wetted Parts & Casing

Ranges

100 mbar to 1000 bar in Gauge, Vacuum & Compound

Applications

Calibration laboratories
Test benches
Process Automation

Technical specification	MG401
Nominal size	100 mm
Measuring Principle	Piezo resistive Sensors
Accuracy	0.1 % F.S. (Accuracy Including Linearity, Hysteresis, Repeatability errors)
Range in bar mbar	-1/0 -1/2 -1/7 -1/10 -1/30 0/70 0/100 0/350 0/700 0/1000 0/100 0/250 0/600
Overpressure limit	130% of scale, Max 1100 bar
Units	bar, mbar, kg/cm ² , psi, Pa, kPa, MPa, mmH ₂ O, mH ₂ O, inH ₂ O (60F), ftH ₂ O, mmHg, cmHg, inHg (60F)
Connection location	Lower
Process Connection	1/2 BSP(M), Others on request.
Display Type Character Height Backlight	LCD, 5 Digit 99999 counts and 6 Digit 999999 counts 0.67" (17 mm) On/Off, Automatic Off function (Never, 10s, 30s, 1 min, 5 min)
Material Case Sensor and Socket	SS 316L SS 316L
Power Battery Life	3 AA Alkaline Battery 2000 Hrs. at standard use
Features	Zero Clear Auto Off Min/Max Indicator Bar Graph (20 Segment) Battery Indication (5 Segment) Update rate (50, 100, 200, 500, 1000 ms) Dampening (None, Low, Medium, High) Tare (User definable) Digit Selection (5/6) Process pressure % indicator (User definable) Password Protection for calibration and special functions (user selectable)
Permissible Ambient temperature Medium temperature Storage temperature Compensated temperature	0 ... 70 °C -10 ... 50 °C -30 ... 80 °C +10 ... 50 °C
Certification	Manufacturer calibration certificate, optional NABL Certificate
Weight	430 grams
Protection	IP65 as per IEC 60529
Accessories	Adapters (Regular/Swivel)

All specifications are subject to change without notice.

IN.MG401 Rev.A 27/06/2022

General dimensions in mm

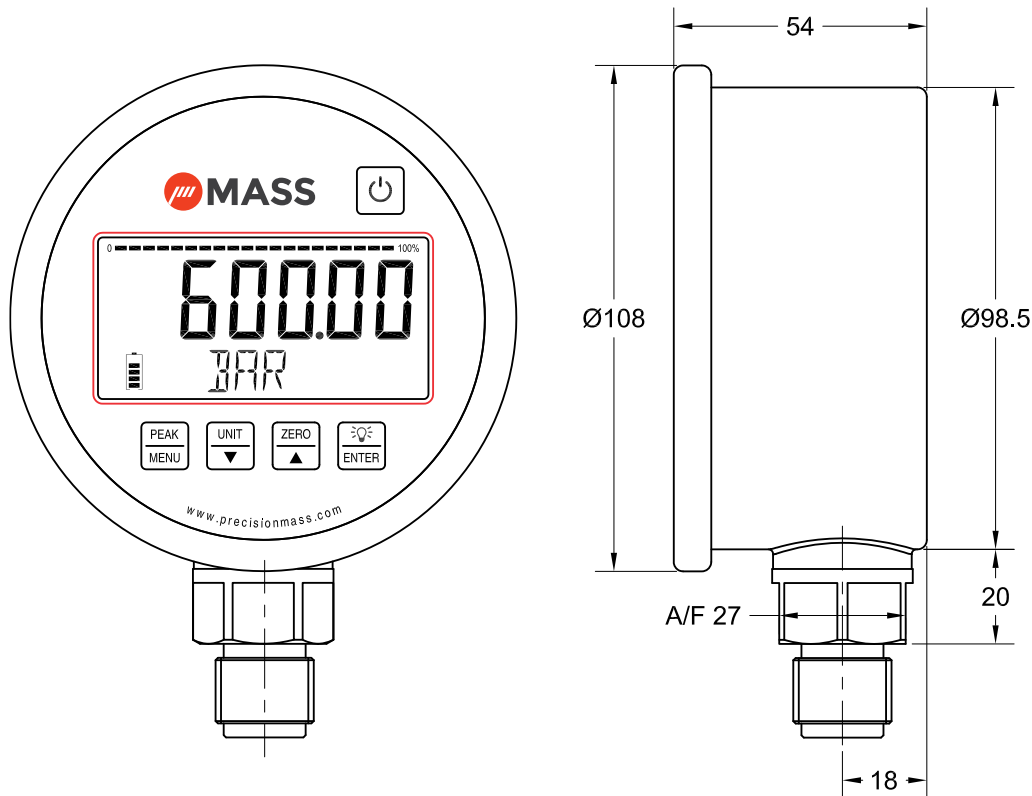

Order information

Size	Type	System Material	Process Connection	Connection orientation	Range	Output	Options
(100) 100mm	MG401	(S) SS316L	(15) 1/2" BSP (M)	(L) Lower	MBAR 0/ 100 0/ 250 0/ 600 BAR -1/ 0 -1/ 2 -1/ 7 -1/ 10 -1/ 30 0/ 70 0/ 100 0/ 350 0/ 700 0/ 1000	(=) None	(TU) Throttle Plug (CD4N) ISO17025 (NABL) Calibration Certificate
			Others on request		Others on request		

How to order

Size	Type	System material	Process connection	Connection orientation	Range	Engineering unit	Output	Option
100	MG401	S	15	L	0/100	BAR	=	TU

Precision Mass Products Pvt. Ltd.

Plot No.: 2306, G.I.D.C. Chhatral, Ta: Kalol, Dist.: Gandhinagar,
Chhatral -382729, Gujarat, India.

Telephone: +91-2764 233681

Email: sales@precisionmass.com

+91-9377407922

www.precisionmass.com